



**ТАХИОН**  
ПРОИЗВОДСТВЕННАЯ ФИРМА

( )

\_\_\_\_\_

\_\_\_\_\_

- : \_\_\_\_\_

(812)-327-1247, 327-1298, 327-1201, 327-1153 10.00 17.00

- 1/3 -

.468121.007-01



RU. 46. 16516

-1/3-  
3U19-16

1. ....10,8 ÷ 14 DC.
2. ....40.
3. ....3.
4. ....50 ÷ 6
5. ....0,5 ÷ 2.
6. ....0 ÷ 6.
7. ....1,0.
8. ....75.
9. ....- 40 ÷ +50.
10. ....95 40 51.

1. 1
2. 1
3. 1

-1/3- :

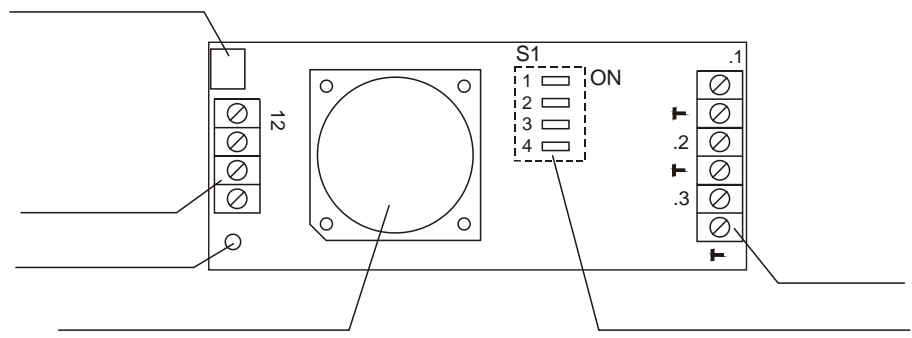

	S 1.1	S 1.2	S 1.3	S 1.4 *)
0	-	-	-	+
1	+	-	-	+
2	-	+	-	+
3	+	+	-	+
4	+	-	+	+
5	-	+	+	+
6	+	+	+	+

: «+» - «ON».  
 «-» - «OFF».  
 \*) - S 1.4 «ON»  
 75

-1/3- ( 5- ),  
 S1.4 -1/3- «OFF».

-1/3- 12

-1/3- ;